

GX GF Series

GX-400
with optional glass breeze break

GX-600
with standard breeze break



AND ...Clearly a Better Value
A&D Company, Limited
<http://www.aandd.jp>

The World's

Our revolutionary Super Hybrid Sensor (SHS) technology improves response speed, accuracy and minimizes maintenance costs. SHS combines the best of magnetic force restoration and single point parallelogram load sensing technologies. Its unique design provides the fastest response speed in its class – just 1 second! And if the time ever comes when the SHS needs repair, you just replace one of three parts – there is no need to replace the whole sensor! This translates to Minimum Maintenance Costs. (An additional benefit of our new SHS is that the GX automatically performs self calibration using the internal mass when the balance detects ambient temperature changes.)

SHS
Super Hybrid Sensor

**Super Hybrid
Sensor**
(Patent Pending)



**Internal Calibration
CAL**

**Motor-driven
Internal Calibration**

Internal Calibration

FDC
Full Digital Calibration

The GX internal calibration with an internal mass saves time and money. External calibration requires a great deal of skill, time and an expensive external mass. With our internal calibration with internal mass, the balance is calibrated very quickly.

- Automatic Self Calibration — Self-calibrates automatically when the balance detects ambient temperature changes.
- One Touch Automatic Calibration — Allows you to calibrate the balance on demand with just the push of a button.
- Calibration is essential for accuracy in weighing. For example, in high resolution balances, changes in sensitivity drift can be caused by changes in the ambient temperature. Take the GX 600 for example, the weight might change by $\pm 0.010\text{g}$ with a change of 10°C . (Sample's weight: 500g)
- The GX's internal calibration mass is adjusted to an "OIML F1 class level." by the standard balance calibrated with an "OIML E2 class level mass". (The GX's internal calibration mass is not "the standard mass for legal metrology" nor "OIML's level of calibration mass." Instead it is the mass for adjustment.)

Just 1 Second — Ultra Fast Response Speed

- Ultra Fast Response Speed—Just 1 Second.* Ideal for installation with filling machines. * "FAST" setting
- Ultra High Performance with minimum maintenance costs.

Standard RS-232C

RS-232C
STANDARD

Incorporates bi-directional communication with a PC, printer or other peripheral device.

Standard Windows Communication Tools Software WinCT

WinCT

A free copy of WinCT-A&D's powerful and flexible data collection software tool for virtually instant connection to a PC and a network of other devices.

Most User-Friendly

GX



GFF



SHS
Super Hybrid Sensor

Internal Calibration
CAL

888
VFD Display

FDC
Full Digital Calibration

RS-232C
STANDARD

WinCT

COMPARATOR

GLP

AAAI
Automatic Counting
Accuracy Improvement

OFF
ANIMAL

y Balances...

888
VFD Display



Bright, bold, blue vacuum fluorescent display (VFD) that is virtually unmistakable from any viewing angle.

ANIMAL



Animal Weighing Mode allows you to quickly and accurately determine the weight of any live or unstable subject. Optional animal weighing pan (GX-12) is available.



Automatic Adjustable Environment Setting Adapts to the most suitable Environment Response Setting automatically with one-touch key operation. The response annunciator displays "FAST", "MID" and "SLOW." (GX)

Manual Response Adjustment can be set by pressing the MODE key and response speed can be adjusted to FAST, MID or SLOW.

COMPARATOR



Standard Comparator Function offers increased flexibility and compatibility for a vast number of applications. You can input a target weight and weigh heavier or lighter items using either the keyboard or by placing samples on the pan. Hi, OK or Lo will be indicated on the display to show the comparison results. (GX-04 Comparator output)

ACAI



Automatic Counting Accuracy Improvement (ACAI) is a novel and useful approach to ensuring the utmost in performance when counting even the smallest of items. ACAI automatically updates and refines the average piece weight used to determine the total quantity.



Percentage Function facilitates an effective and quick comparison of a sample or commodity against a known reference mass. Simply place an object on the pan to register its weight as 100%. Place another object on the pan to compare its weight in percentage mode.



Overall Capacity Indication is a unique and helpful feature. By indicating how much of the balance's capacity has been filled, the risk of overloading the balance is minimized.

Main Features

GXseries

GFseries

SHS (Super Hybrid Sensor)	✓	✓
Internal Calibration	✓	—
VFD Display	✓	✓
WinCT	✓	✓
Data Memory Function	✓	✓
Automatic Adjustable Environment Setting	✓	(Manual)
Auto Self Checking	✓	✓
Density Determination Function	✓	✓
Quick Reference Card	✓	✓
Underhook	✓	✓
Time & Date Function	✓	—
Large Square Weighing Pan	✓	✓
Comparator Function	✓	✓
Animal Weighing	✓	✓
Capacity Indicator	✓	✓
ACAI Counting Function	✓	✓
Percentage Function	✓	✓
Front Air Bubble Leveling	✓	✓
Standard RS-232C	✓	✓
GLP, GMP, GCP, ISO Compliance Data Output	✓	✓
Splash Proof Keyboard and Display	✓	✓
Display Auto Power Off Function	✓	✓
Aluminum Die-Cast Case	✓	✓

Splash Proof Keyboard and Display

Balances protected from dust and spills

GLP GLP/GMP/GCP/ISO Compliance

Allows GLP or LIMS balance management by outputting the Balance ID number and data used to calibrate the balance. The data can be output to A&D's AD-8121B printer or a computer, indicating date, time, Balance ID number, serial number and calibration data.

```
A & D
MODEL:  GX-2000
S/N:    01234567
ID:     ABCDEF0
DATE:   2003-01-01
TIME:   12:34:56
CALIBRATED<INT.>
SIGNATURE
```



Standard RS-232C

Bi-directional communication with a PC or connects directly to a printer

Commands

A PC can control the balance by sending commands to the balance.

- Commands to query weighing data
- Commands to control the balance
- Commands to control the memory function
- Commands to control the comparator function

ID Number

The balance ID number can be set. It is used to identify the balance when GLP is used. The ID number is memorized and maintained once it is fixed, even if the AC adapter is removed.

OFF Display Auto Power Off Function

Display turns off after 10 minutes of inactivity (can be disabled when undesired)

Data Memory Function (Patent Pending)

Format the Data Memory Function for:

- GX • 200 sets of weighing data
 - 100 sets of weighing data with Time & Date
 - 50 sets of GLP Data–Time & Date, Calibration Data, ID number and Serial number
 - 20 sets of Unit Weight for Counting Mode
- GF • 40 sets of weighing data
 - 20 sets of Unit Weight for Counting Mode

Time & Date (GX only)

Standard Time & Date Function complies with GLP and Interval Weighing in the Data Memory Function

Auto Self Checking

Automatically checks itself when setting the Automatic Adjustable Environment

Standard Underhook

Ideal for density determination and weighing magnetic substances.

Density Measurement Function

Picture shown with GX-13 Density Measurement Kit



Interval Time Setting

Weighing intervals of 2, 5, 10, 30 seconds and 1, 2, 5, 10 minutes in the Data Memory Function

Auto Power On Function

Plug it in and it turns itself on without pressing ON/OFF key

Auto Re-Zero Function

Re-Zeroes automatically after data output

Large Square Weighing Pan

Standard large square weighing pan on all models
128 x 128mm for 0.001g resolution models
165 x 165 mm for 0.01g and 0.1g resolution models

Multiple Weighing Units & Programmable Unit

Uses Programmable or standard units of measure (g, ct, dwt etc.)

Front Air Bubble Leveling

Easily check the balance's level from the front

Quick Reference Card

A fast, convenient operating guide installed at the bottom of the balance



Specifications

	GX-200	GX-400	GX-600	GX-800	GX-1000		GX-2000	GX-4000	GX-6100	GX-6000	GX-8000		
	GF-200	GF-300	GF-400	GF-600	GF-800	GF-1000	GF-1200	GF-2000	GF-3000	GF-4000	GF-6100	GF-8000	
Weighing capacity	210g	310g	410g	610g	810g	1100g	1210g	2100g	3100g	4100g	6100g	8100g	
Minimum weighing value	0.001g						0.01g						
Repeatability (Standard Deviation)	0.001g						0.01g						
Linearity	±0.002g			±0.003g			±0.02g			±0.03g			
Stabilization time (typical at FAST)	Approx. 1second			Approx. 1.5 seconds			Approx. 1second			Approx. 1.5seconds			
Sensitivity drift (10°C to 30°C/50°F-80°F)	±2ppm/oC (When automatic self calibration is not used)												
Operating temperature	5°C to 40°C (41°F to 104°F), 85%RH or less (No condensation)												
Sensing method	Super Hybrid Sensor (SHS) *SHS: Patent issued and pending												
Display type	Vacuum Fluorescent Display (VFD)												
Display refresh rate	5times/second or 10times/second												
Counting mode	Minimum unit mass	0.001g						0.01g					
	Number of samples	10, 25, 50 or 100pieces											
Percent mode	Minimum 100% reference mass	0.100g						1.00g					
	Minimum 100% display	0.01%, 0.1%, 1% (Depends on reference mass stored)											
Standard serial I/F	RS-232C Interface with Windows Communication Tools (WinCT: included as CD-ROM)												
Weighing pan	128 x 128 mm (5.04 x 5.04inch)						165 x 165 mm (6.50 x 6.50inch)						
Calibration	Motor-driven Internal Calibration (GX only)												
External dimensions	210(W) x 317(D) x 86(H)mm (8.27 x 12.48 x 3.39inch)												
AC adapter	Confirm that the adapter type is correct for the local voltage and power receptacle												
Power consumption	Approx. 11VA (supplied by AC adapter)												
Net weight	Approx. 4.6kg(GX) / 3.8kg(GF)						Approx. 5.1kg(GX) / 4.3kg(GF)						

Notes: The internal mass is equal to (approximately) 500grams.
 EC Type Approval Confirmed (Approval No. UK2560)
 Standard Breeze break included for 1mg Minimum weighing value models

Options

- GX-04* Comparator Output with a Buzzer/
RS-232C/Current Loop Output
 - GX-06* Analog Output/Current Loop Output
 - GX-10 Glass Breeze Break for 128 x 128mm
weighing pan size models
 - GX-11 Glass Breeze Break for 165 x 165mm
weighing pan size models
 - GX-12 Animal weighing pan
(not applicable for GX-200 and GF-200)
 - GX-13 Density Determination Kit for 128 x 128mm
weighing pan size models
- * 04& 06 cannot co-exist
 * Factory installed option

Accessories

- AD-8121B Dot Matrix Compact Printer
- AD-8118B Universal Printer
- AD-8920 Remote Display
- AD-8922 Remote Controller
- AD-1682 Rechargeable Battery Unit
(Maximum operating time: 8hours)
- AD-1683EX Static Eliminator
- AX-KO1710-200 RS-232C Cable (25P-9P)
- AX-SW-128 Foot Switch
- AX-073003691-S Dust cover for 128 x 128mm
weighing pan size models
- AX-073003692-S Dust cover for 165 x 165mm
weighing pan size models

Physical Dimensions (mm)

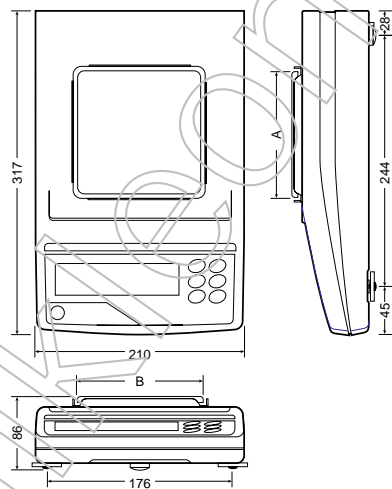

Pan size (mm)

Model	A	B
GX-200/400/600/800/1000	128	128
GF-200/300/400/600/800/1000		
GX-2000/4000/6100/6000/8000	165	165
GF-1200/2000/3000/4000/6100/6000/8000		

Approx. 1 second

Dimensions With Optional Glass Breeze Break (mm)

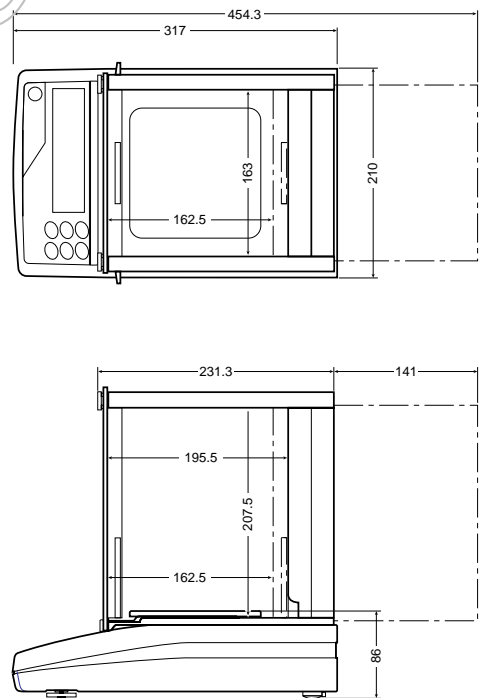

Specifications subject to change for improvement without notice.

A&D ...Clearly a Better Value

A&D Company, Limited

3-23-14 Higashi-Ikebukuro, Toshima-ku, Tokyo 170-0013 JAPAN
 Telephone:[81](3) 5391-6132 Fax:[81](3) 5391-6148
 http://www.aand.jp

A&D ENGINEERING, INC.

1555 McCandless Drive, Milpitas, CA. 95035 U.S.A.
 Telephone:[1](408) 263-5333 Fax:[1](408) 263-0119

A&D MERCURY PTY. LTD.

32 Dew Street, Thebarton, South Australia 5031 AUSTRALIA
 Telephone:[61](8) 8301-8100 Fax:[61](8) 8352-7409

A&D INSTRUMENTS LTD.

Unit 24/26 Blacklands Way Abingdon Business Park,
 Abingdon, Oxon OX14 1DY United Kingdom
 Telephone:[44](1235) 550420 Fax:[44](1235) 550485

<German Sales Office>

Große Straße 13 b 22926 Ahrensburg GERMANY
 Telephone:[49](0) 4102 459230 Fax:[49](0) 4102 459231

A&D KOREA Limited

Manhattan Bldg. 8F, 36-2 Yoido-dong, Youngdeungpo-gu, Seoul, KOREA
 Telephone:[82](2) 780-4101 Fax:[82](2) 782-4280