

Production flow chart by items

Dice

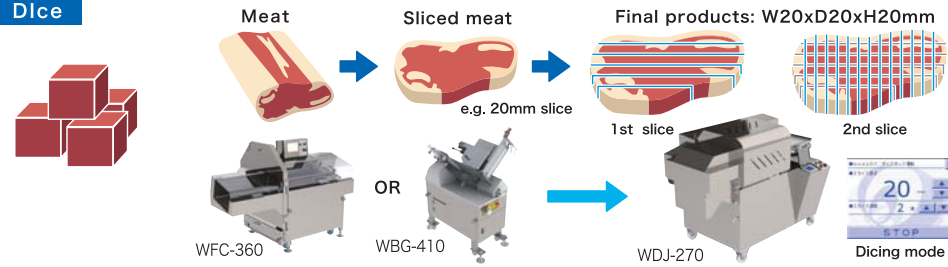

Chip

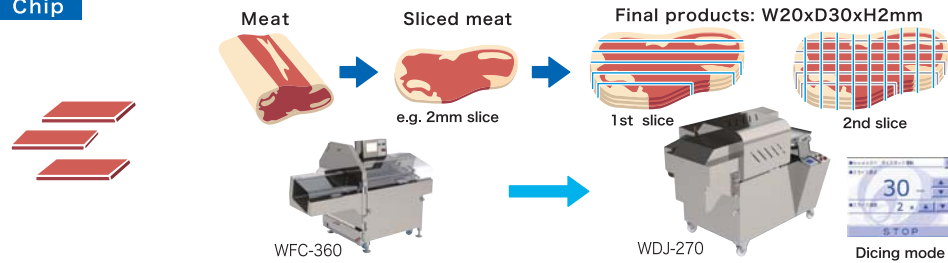

Rectangle

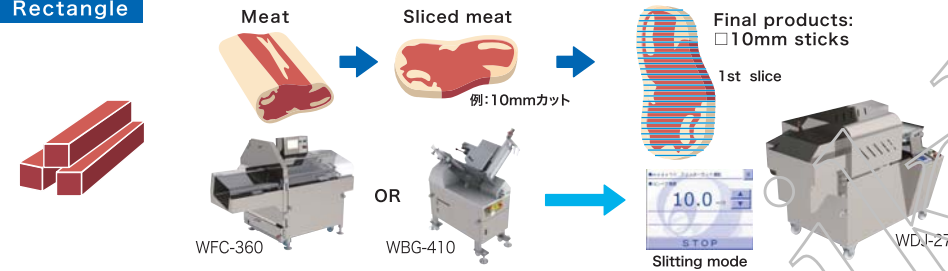

■ SPECIFICATION

Dimensions	W1,460xD870xH1205mm
Weight	300kg
Max. slice size	W270mm x H: same as 1st slice width
1st slice	Standard 10/20/30mm Option 15/25mm
2nd slice	5~70mm
2nd slice speed	5 gears (1st 100/min. 2nd 150/min. 3rd 200/min. 4th 250/min. 5th 300/min.)
Slice temperature	-3~0°C (depends on products)
Rating electricity	Inlet 1.21kW Rating electric current 6.3A
Rating power consumption	0.31kW (50/60Hz with no overloaded)
Power supply	3P 200V 50/60Hz 20A

■ DRAWING Please refer to the drawing for further information.

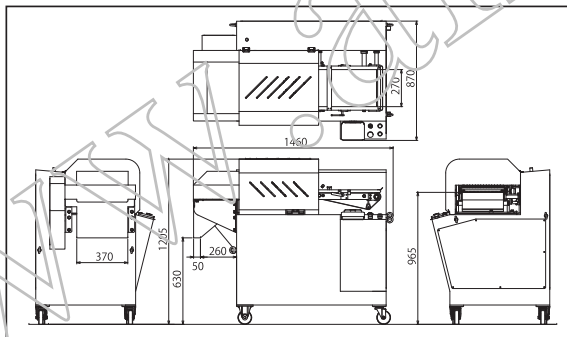

SALES AGENT

WATANABE
WATANABE FOODMACH CO., LTD.

2-12-26 TSUYUHASHI NAKAGAWA-KU NAGOYA JAPAN
TEL 052-361-8511 FAX 052-361-8490
URL: <http://www.foodmach.co.jp/>

WATANABE

MULTI DICER J270 WDJ-270

Dice, Rectangle, Chip - Flexible Slicer

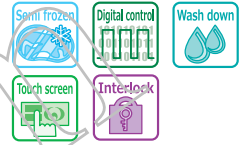

1st slice

Various slices will be available by changing the blade frame and cassette. Such as 10mm, 20mm, 30mm. ※Please order your size.



Option

15mm, 25mm can be made for you.

15mm set

25mm set



15mm cassette + 15mm frame

25mm cassette + 25mm frame

※Cassette and frame is always a set.

Simple operation

The touch screen is friendly for everybody.

Also the control screen even navigate the way to remove parts for cleaning up the machine.



2nd slice

Products will be fed with holding by the upper and lower feeding belt after 1st slice. It is easy to size by touching the control screen.



Visible & Safety interlock system

There are the interlock system for the blade cover, feeding part and outlet cover. All of the condition can be visible with the control screen.

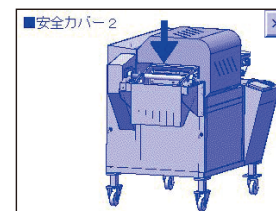
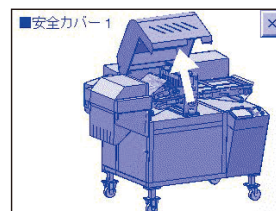

Sanitary engineering

No tool is needed for removing parts. Now washing down is available! Less stress for cleaning after the operation.

