

SUPER DELUXE DX/ST WSD-DX/ST

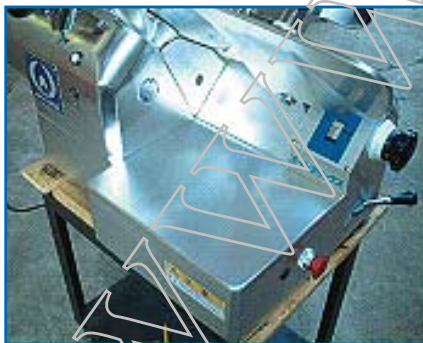

SAFETY, ACCURATE AND EFFICIENT SLICER.



United frame with no spaces!
Easy to be cleaned!



A stainless-made products
pusher is clean and it can
hold the products more than
before.



United blade cover! Easy to
be cleaned!

OPERATION

- ◆ ACCURACY... Easy thickness adjustment (1~20mm). It is possible to slice without much waste.
- ◆ CLEAN... The stainless steel and coating steel are always shining. Easy construction for cleaning by detachable parts!

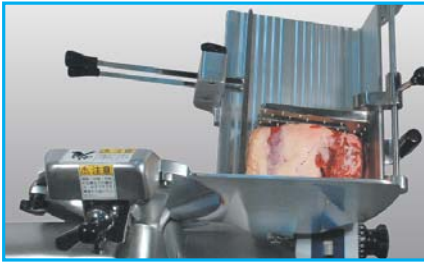

Put a product on the meat carriage.



Adjust the thickness and start to slice.

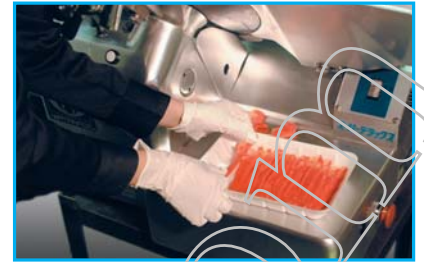

Everybody has uniform quality slices.

TAKEN A PART CLEANING



Easy everyday maintenance by easily taking a part.

UNIFORM CONSTRUCTION



Wider space and cleaner than before.

VARIOUS OPTIONS



Safety magnet blade cover will give you the best safety for your cleaning time.

SLANT MEAT CARRIAGE OPTION

D-T45

The slant meat carriage helps to wide your slicing range. (Optional)



■ DRAWING

Please refer to the drawing for further information.

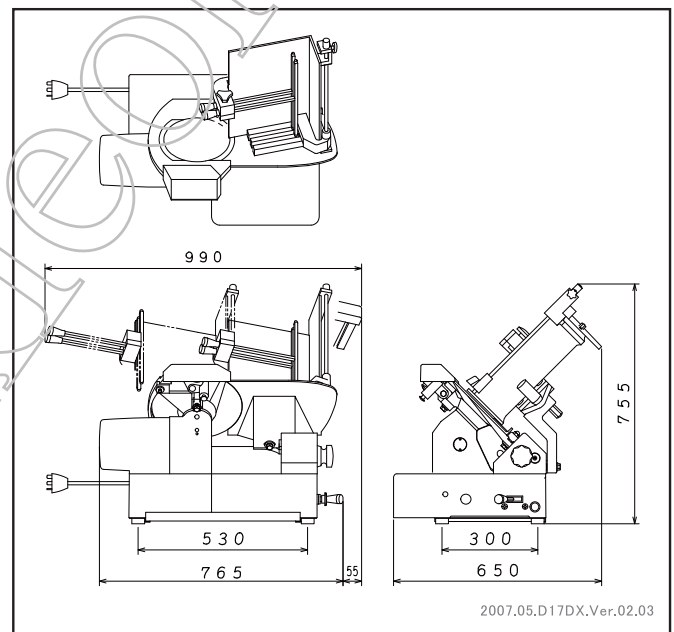

■仕様

MODEL	WSD-DX	WSD-ST
DIMENSIONS	W765×D650×H755mm	
POWER SUPPLY	3P 200V 0.75kW	1P 100V 0.25kW
PROCESSING CAPACITY	40PCS/MIN.(50Hz)	48PCS/MIN.(60Hz)
MAXIMUM SIZE OF SLICES	W220×H140XL390mm	
PROCESSING TEMPERATURE	-4~5°C	
SLICING THICKNESS	0~20 mm	
MACHINE WEIGHT	65 kg	



SAFETY CAUTION

- Attention on the treatment of the blade.
- The earth cable must be connected.
- Never splash the water in the machine.
- Set the safety guard for preventing any danger from the back and forth motion of the meat carriage.
- The born-in-meat must not be sliced.
- The hard frozen meat must not be sliced.
- Attention on the driving and rotating part of the machine.

WATANABE
WATANABE FOODMACH CO.,LTD.
コナベフマック株式会社

2-12-26 TSUYUHASHI NAKAGAWA-KU NAGOYA JAPAN
TEL052-361-8511 FAX052-361-8490
URL: <http://www.foodmach.co.jp/>

SALES AGENT